

POLISH SURFACE inside  $\varnothing 25$  Ra 0.4  
 SPIRAL FREE GRINDING.  
 UNIFORM CIRCULAR FINISH REQUIRED.  
 RANDOM SCRATCHES AND MACHINING MARKS  
 NOT PERMITTED

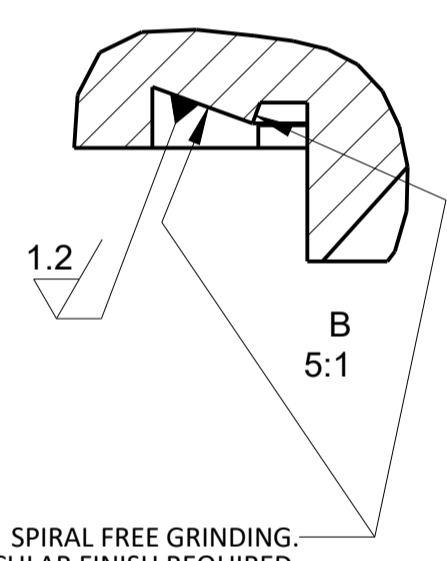

SPIRAL FREE GRINDING.  
 UNIFORM CIRCULAR FINISH REQUIRED.  
 RANDOM SCRATCHES AND MACHINING MARKS  
 NOT PERMITTED.

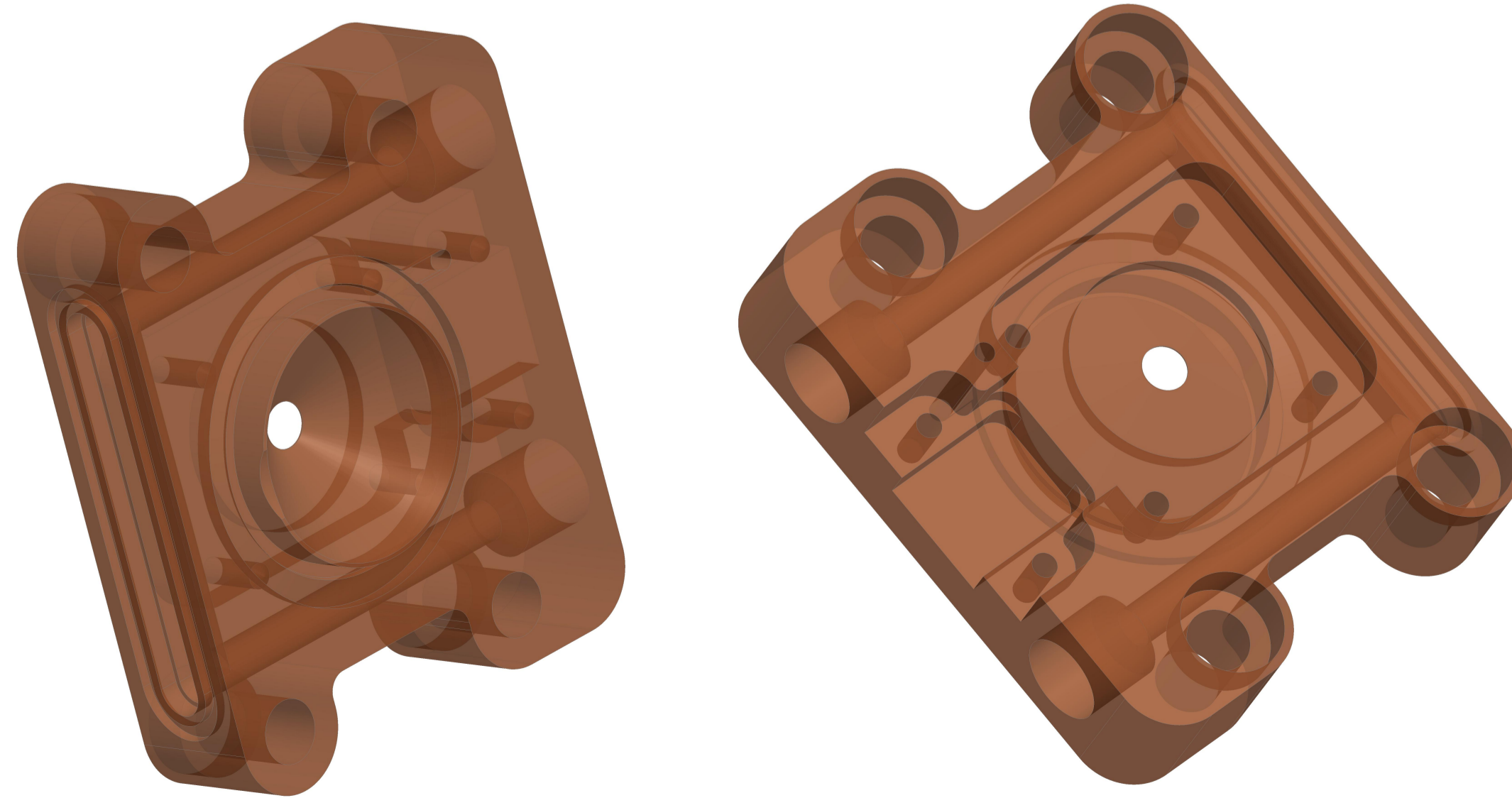
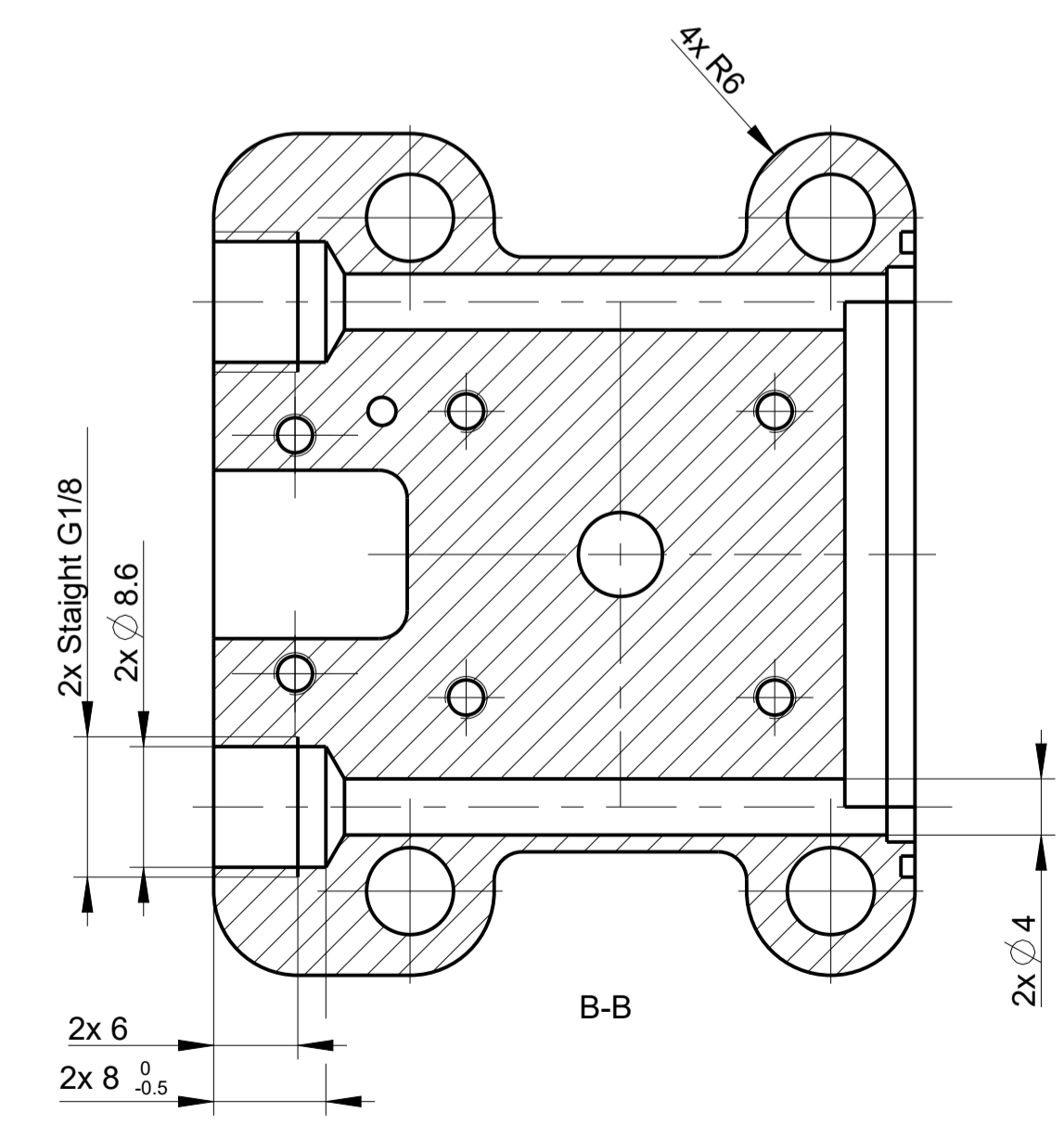
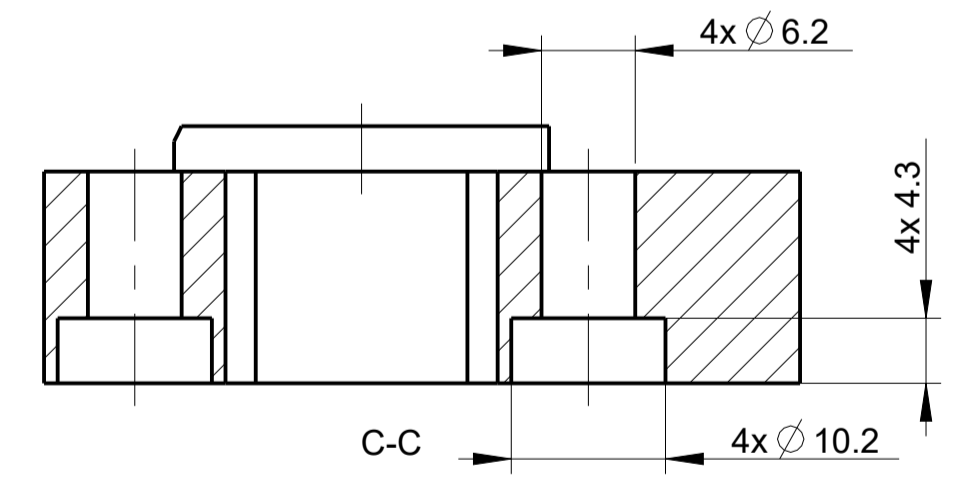
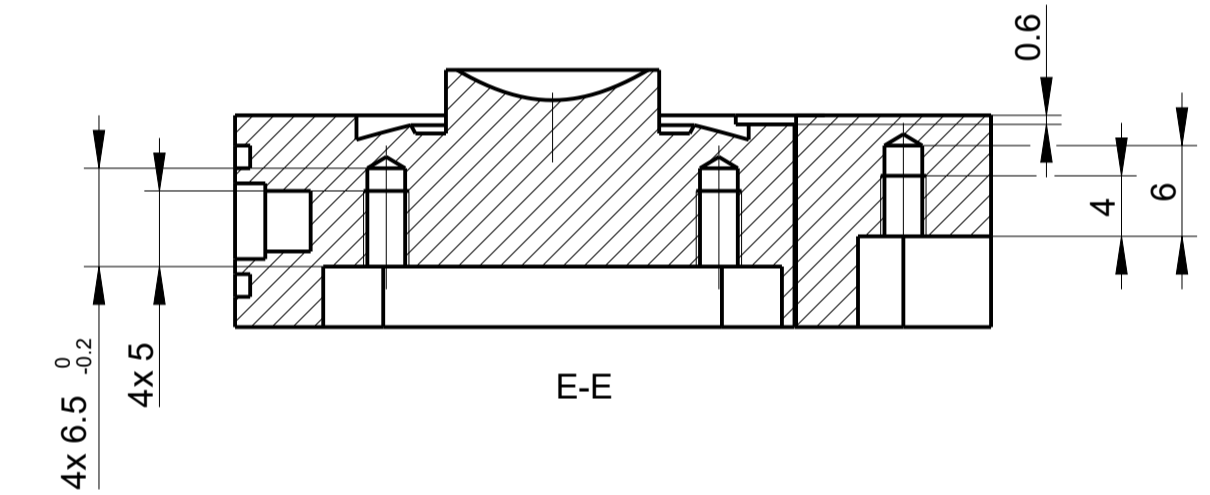
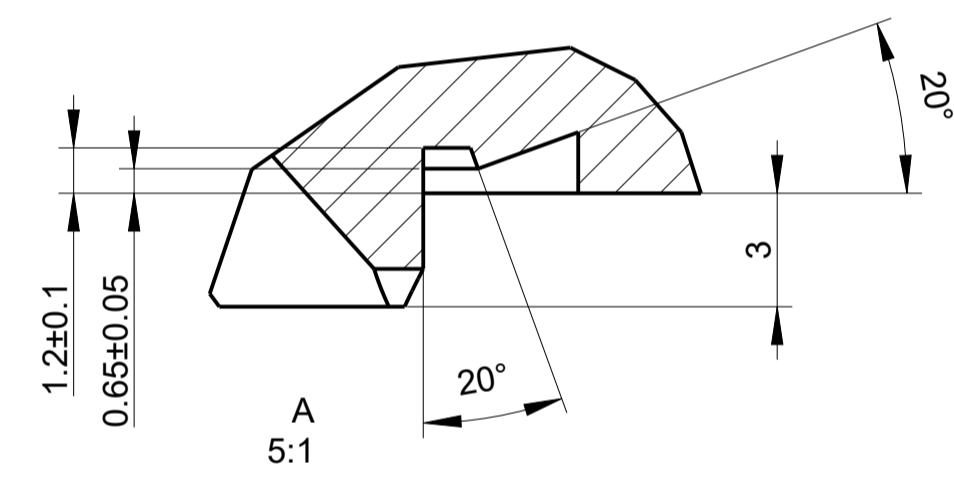
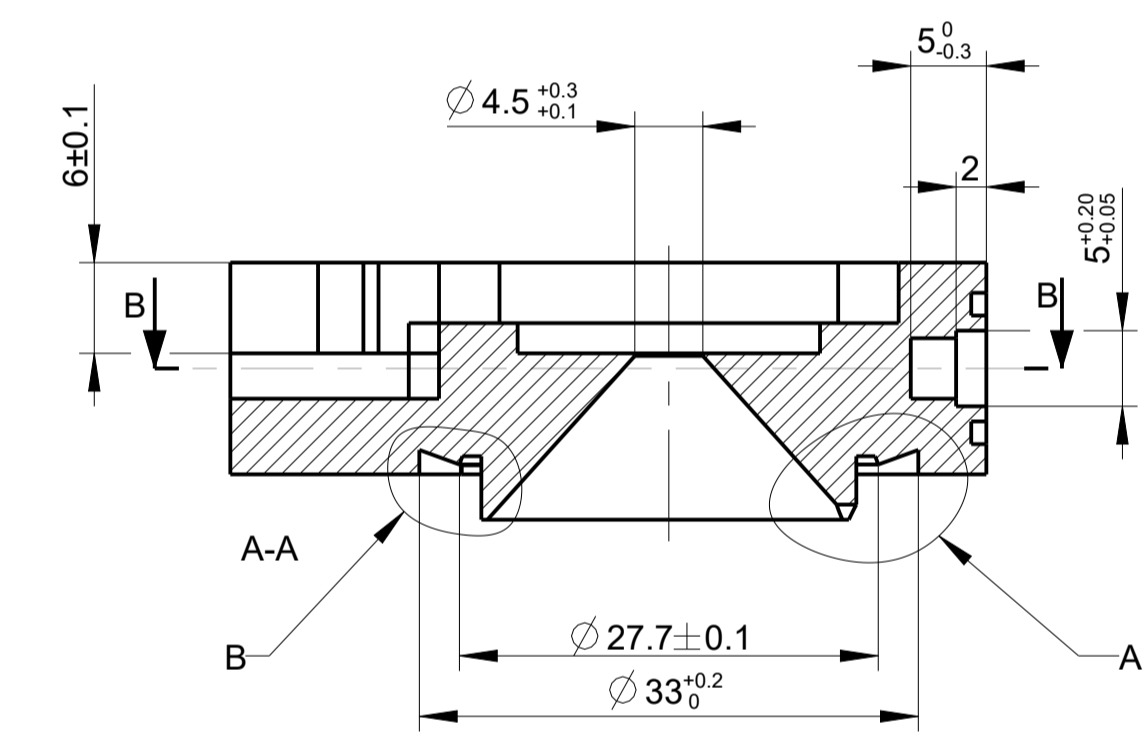

Where otherwise not stated:  
 Gen. tolerance according to ISO 2768-mK  
 Surface roughness Ra 3.2  
 All edges chamfered R=0.3±0.2  
 All dim. to be valid after surface treatm.  
 Detail must be clean at delivery

Surface treatment	-		
Heat treatment	-		
Material	EN CW106C, UNS C18150 (CuCr1Zr)		
	Designed date	20150511	Designer
	Name		Approved for
	R7 WINDOW FRAME		Scale
	Drawing number	D-034-0303	Sheet
			1(1)
			Revision
			2